

## APPENDIX A:

# SOFTWARE LICENSE AGREEMENT

This is a legal license agreement between you (an individual or an entity), the end user, and INNOVENTIONS, Inc. Please read this license agreement carefully before using the Software. Using the enclosed software indicates that you accept these terms. If you do not agree to the terms of this Agreement, promptly return the unused software to the point of purchase and your money will be refunded.

1. **The Software.** INNOVENTIONS' software programs are used on a personal computer as a real-time interface to the RAMCHECK and as a downloader for updating the RAMCHECK firmware. The software is supplied on a CD in the original RAMCHECK package, while updated portions of the software are available on the INNOVENTIONS' Internet Web site (<http://www.innoventions.com>).

The INNOVENTIONS software programs (the "Software") which are enclosed with this package or are available on INNOVENTIONS' Internet Web site (the "Site") are intended for use with the INNOVENTIONS' RAMCHECK product line (the "RAMCHECK") and are licensed by INNOVENTIONS to the original RAMCHECK customer and any subsequent transferee of the product for use only on the terms set forth here.

2. **Grant of License.** This INNOVENTIONS Software License Agreement ("License") permits you to use one copy of the Software on any single computer, provided that you have purchased a RAMCHECK unit. The Software is "in use" in a computer when it is loaded into the temporary memory (i.e., RAM) or is installed into the permanent memory (i.e. hard disk) of that computer.

3. **Copyright.** The Software is owned by INNOVENTIONS or its suppliers and is protected by United States copyright laws and international treaty provisions. Therefore, you must treat the Software like any other copyrighted material (e.g., a book or musical recording), except that you may either (a) make one copy of the Software solely for backup or archival purposes, or (b) transfer the Software to a single hard disk provided you keep the original solely for backup or archival purposes. You may not copy written materials accompanying the Software.

4. **Other Restrictions.** This License is your proof of license to exercise the rights granted herein and must be retained by you. You may not rent or lease the Software, but you may transfer your rights under this License on a permanent basis provided that you transfer your RAMCHECK unit, this License, the Software and all accompanying written materials, you retain no copies, and the recipient agrees to the terms of the License.

You may not reverse engineer, decompile, disassemble, or create derivative works from the SOFTWARE.

**5. Technical Support and Software Upgrades.** Licensee must register in order to be eligible for technical support via telephone or electronic mail. Registration should be made by mailing the enclosed registration card or by registration via INNOVENTIONS' Web site. Upon registration and for a period of one year, commencing with date of Licensee's first download of an upgrade, Licensee will be eligible to download Software upgrades, which may be available on the INNOVENTIONS' Web site. Upon the expiration of the above-described one-year period, Licensee may extend the download privilege on an annual fee basis.

**6. Limited Warranty on CD.** INNOVENTIONS warrants the CD on which the Software is recorded to be free from defects in materials and workmanship under normal use for a period of one year from the date of purchase of the RAMCHECK unit. INNOVENTIONS' entire liability and Licensee's exclusive remedy will be replacement of the CD not meeting INNOVENTIONS' limited warranty and which are returned to the place of purchase within such warranty period. ANY IMPLIED WARRANTIES ON THE CD INCLUDING THE IMPLIED WARRANTIES OF MERCHANTABILITY AND FITNESS FOR A PARTICULAR PURPOSE ARE LIMITED IN DURATION TO ONE YEAR FROM THE DATE OF PURCHASE.

**7. Disclaimer of Warranty.** Licensee expressly acknowledges and agrees that the use of the Software and its documentation is at Licensee's sole risk. The Software, documentation, and technical support are provided "AS IS" and without warranty of any kind. Information regarding any third party services included in this package is provided as convenience only, without warranty by INNOVENTIONS, and will be governed solely by the terms agreed upon between Licensee and the third party providing such services. TO THE MAXIMUM EXTENT PERMITTED UNDER APPLICABLE LAWS, INNOVENTIONS AND INNOVENTIONS' LICENSER(S) (FOR THE PURPOSES OF PROVISIONS 8 AND 9, INNOVENTIONS AND INNOVENTIONS' LICENSER(S) SHALL BE COLLECTIVELY REFERRED TO AS INNOVENTIONS) EXPRESSLY DISCLAIM ALL WARRANTIES, EXPRESSED OR IMPLIED, INCLUDING, BUT NOT LIMITED TO THE IMPLIED WARRANTIES OF MERCHANTABILITY, FITNESS FOR A PARTICULAR PURPOSE, AND NONINFRINGEMENT. INNOVENTIONS DOES NOT WARRANT THAT THE FUNCTIONS CONTAINED IN THE SOFTWARE WILL MEET LICENSEE'S REQUIREMENTS, OR THAT THE OPERATION OF THE SOFTWARE WILL BE UNINTERRUPTED OR ERROR-FREE, OR THAT DEFECTS IN THE SOFTWARE WILL BE CORRECTED. FURTHERMORE, INNOVENTIONS DOES NOT WARRANT OR MAKE ANY REPRESENTATIONS REGARDING THE USE OR THE RESULTS OF THE USE OF THE SOFTWARE OR ITS DOCUMENTATION IN TERMS OF THEIR CORRECTNESS, ACCURACY, RELIABILITY, OR OTHERWISE. NO ORAL OR WRITTEN INFORMATION OR ADVICE GIVEN BY INNOVENTIONS OR ITS AUTHORIZED REPRESENTATIVE SHALL CREATE A WARRANTY OR IN ANY WAY INCREASE THE SCOPE OF THIS WARRANTY.

SOME JURISDICTIONS DO NOT ALLOW THE EXCLUSION OF IMPLIED WARRANTIES, SO THE ABOVE EXCLUSION MAY NOT APPLY.

**8. Limitation of Liability.** TO THE MAXIMUM EXTENT PERMITTED UNDER APPLICABLE LAWS, UNDER NO CIRCUMSTANCES, INCLUDING NEGLIGENCE, SHALL INNOVENTIONS, ITS DIRECTORS, OFFICERS, EMPLOYEES OR AGENTS BE LIABLE FOR ANY INCIDENTAL, SPECIAL OR CONSEQUENTIAL DAMAGES (INCLUDING DAMAGES FOR LOSS OF BUSINESS PROFITS, BUSINESS INTERRUPTION, LOSS OF BUSINESS INFORMATION AND THE LIKE) ARISING OUT OF THE USE OR INABILITY TO USE THE SOFTWARE OR ITS DOCUMENTATION, EVEN IF INNOVENTIONS OR ITS AUTHORIZED REPRESENTATIVE HAS BEEN ADVISED OF THE POSSIBILITY OF SUCH DAMAGES. SOME JURISDICTIONS DO NOT ALLOW THE LIMITATION OR EXCLUSION OF LIABILITY FOR INCIDENTAL OR CONSEQUENTIAL DAMAGES SO THE ABOVE LIMITATION OR EXCLUSION MAY NOT APPLY.

In no event shall INNOVENTIONS' total liability to Licensee for all damages, losses, and causes of action (whether in contract, tort, including negligence, or otherwise) exceed the amount paid by Licensee for the Software and its documentation.

**9. Government Restricted Rights.** If you are acquiring the Software on behalf of any unit or agency of the United States Government, the following provisions apply:

The Government acknowledges INNOVENTIONS' representation that the Software and its documentation were developed at private expense and no part of the m is in the public domain. The Government acknowledges INNOVENTIONS' representation that the Software is "Restricted Computer Software" as that term is defined in Clause 52.227-19 of the Federal Acquisition Regulations (FAR) and is " Commercial Computer Software" as that term is defined in Subpart 227.471 of the Department of Defense Federal Acquisition Regulation Supplement (DFARS). The Government agrees that:

(i) if the Software is supplied to the Department of Defense (DoD), the Software is classified as "Commercial Computer Software" and the Government is acquiring only "restricted rights" in the Software and its documentation as that term is defined in Clause 252.227-7013 (c) (1) of the DFARS, and (ii) if the Software is supplied to any unit or agency of the United States Government other than DoD, the Government's rights in the Software and its documentation will be as defined in Clause 52.227-19 (c) (2) of the FAR.

**RESTRICTED RIGHTS LEGEND.** Use, duplication, or disclosure by the Government is subject to restrictions as set forth in subparagraph (c) (1) (ii) of the Rights in Technical Data and Computer Software clause at DFARS 252.227-7013. Contractor/manufacturer is INNOVENTIONS, Inc. 10425 Bissonnet Street, Houston, TX 77099.

**9. GENERAL.** This Agreement will be governed by the laws of the State of Texas, except for that body of law dealing with conflicts of law. Should you have any questions

concerning this Agreement, or if you desire to contact INNOVENTIONS for any reason, please write: INNOVENTIONS, Inc. 10425 Bissonnet Street, Houston, TX 77099.

## APPENDIX B:

### RAMCHECK TEST ALGORITHMS

RAMCHECK's proprietary test algorithms were developed for optimum efficiency and fast testing. RAMCHECK utilizes different patterns and different algorithm types whenever the same module is re-tested. Tests are of type  $O(n)$ , using MARCH, CHECKER, WALKING 0s, WALKING 1s and Surround Disturb Patterns.

The complexity of testing a memory chip can be understood from the following example: let us assume that we want to test a simple hypothetical memory chip of only 8 cells. A simple approach is to first write "0" in all the cells and verify that the cells hold the data, and then write "1" in all the cells and verify. Thus in only 16 write/read cycles we have "completely checked" this chip. **However, there is a major flaw** in this conclusion since it is possible that cell number 2 is shorting (or otherwise disturbing) cell 7, and the above test will not detect this!

An alternate approach is to exhaustively test the memory with all possible combination of "0"s and "1"s in all the cells. First we write and verify with all "0"s. Second, we write and verify with "1" in cell 1 and "0"s in all other cells. The third test checks cell 2 with "1", "0"s in all others, etc. Overall, we need to test this hypothetical chip with  $2^8=256$  patterns, since each pattern has at least 8 write/read accesses to the chip. Based on the example above, it will take at least  $[256,000 \times 2^{256,000}]$  accesses to fully test a 256K memory chip. This number is astronomical - and therefore it is theoretically impossible to create a test for a modern memory chip with 100% accuracy.

Fortunately, most inter-cell disturbances in a memory chip occur between adjacent cells, so that a fully exhaustive test as mentioned above is not required.

During the years since our SIMCHECK line of products were first developed, the test algorithms have been continuously improved to achieve unparalleled accuracy in testing memory chips. The proprietary programs, which have been thoroughly tested and refined in SIMCHECK, have been transported to RAMCHECK and have been further improved. For example, using programmable voltage sources, our test algorithms use advanced tests

incorporating Voltage Bounce and Voltage Cycling. The first provides higher accuracy in detecting pattern sensitivity and other intermittent memory problems. The latter provides additional assurance of proper product operation under the entire manufacturer's voltage specifications. Another addition is our Chip-Heat mode, which warms the tested module to true working temperatures, thereby improving the reliability of temperature related measurements. So despite the complexities enumerated above, your RAMCHECK can trap most defective memory modules.

## APPENDIX C:

### SDRAM TIMING AND PC-100/133 COMPLIANCE

The Access Time from Clock (T<sub>ac</sub>) is one of the important timing parameters of the SDRAM memory device and it is critical for PC-100 and PC-133 compliance. This section explains the T<sub>ac</sub> timing parameter, illustrates its dependency on CAS Latency 2 or 3, and explains how the RAMCHECK measurement of this parameter is used to interpret compliance with the PC-133/PC-100/PC-66 standards.

#### Access Time From Clock (T<sub>ac</sub>)

The access time from the clock signal (T<sub>ac</sub>) is dependent on the CAS Latency setup. For CAS Latency 3, the first set of data is valid at the rising edge of the third clock from the read command. For CAS Latency 2, the first set of data is valid at the rising edge of the second clock from the read command. The following drawing illustrates the CAS Latency in a simplified way. It is assumed that the bank ACTIVE command, which is needed to start any SDRAM activity, has been properly initiated prior to the READ command. The read data can be a burst of 1, 2, 4, 8, or even a full page of data, depending on the SDRAM setup. Therefore, CAS Latency determines when the first data is valid.

As shown in the drawing, for CAS Latency 2, the T<sub>ac</sub> parameter is the time from the rising edge of the first clock after the READ command to the time that first data is valid. For CAS Latency 3, the T<sub>ac</sub> parameter is the time from the rising edge of the second clock after the READ command to the time that first data is valid. The access time from clock is also called Output Valid From Clock.

**SIMPLIFIED SDRAM READ OPERATION**

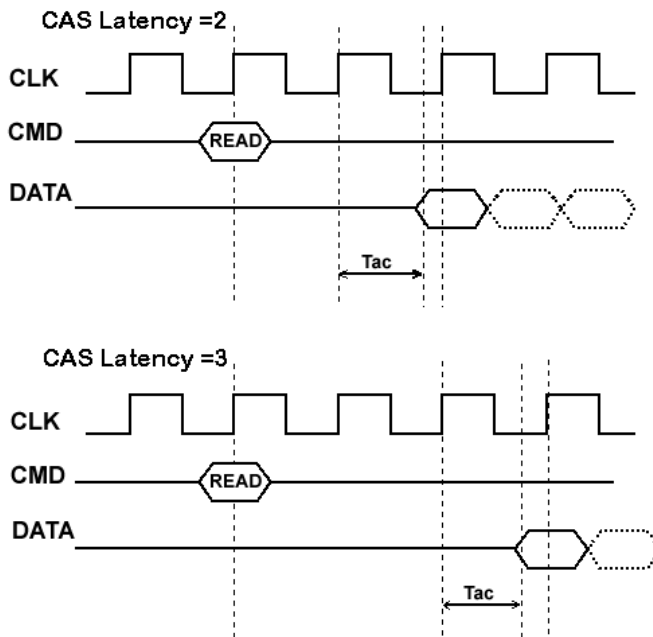

**INTEL PC-100/PC-66 Tac Limits**

Intel specifies the following limits for the Tac parameter:

Output Valid From Clock (Tac)	PC-66	PC-100
CAS Latency=2 Limited Application	10.0 nS	7.0 nS
CAS Latency=2 Full Application	9.0 nS	6.0 nS
CAS Latency=3 Full Application	9.0 nS	6.0 nS

Intel specs acquired from the Intel Serial Presence Detect Specification revision 1.2A; further information can be acquired by visiting Intel's website at:

<http://developer.intel.com/design/pcisets/memory/index.htm>.

**PC-133 Tac Limits**

The PC-133 is essentially based on the INTEL PC-100 specification with the enhancement of 133MHz operation at a CAS Latency of 3 (CL=3) and access time from clock (Tac) of 5.4nS. Accordingly, the SPD data of a PC133 module is similar to the PC-100 SPD data, with the exception of byte 9 (SDRAM device cycle time CL=3) set to 75h (7.5nS) and byte 10 (SDRAM device access time from clock at CL=3) set to 54h (5.4nS).



### RAMCHECK Tac Measurements

At the start of the Basic test, RAMCHECK measures the module's Tac at CAS Latencies of two and three. If the module has two banks, RAMCHECK takes the slower measurements (higher access time in nS) into account. The program uses specific margins to determine if the tested module exhibits Tac in the range of the PC-133, the PC-100 standard or the PC-66 standard. These measurements are shown in the SPEED summary screen at the end of the Basic test (or if you press F5 during Basic test) as follows:

```
8Mx64'S SPEED:
Tac (CL=3): 8.5nS
Tac (CL=2): 8.0nS
83MHZ <PC-66>
```

```
16Mx64'S SPEED:
Tac (CL=3): 5.0nS
Tac (CL=2): 5.5nS
100MHZ <PC-100>
```

The same data is also recorded in the Test Log as follows:

```
ACCESS TIME FROM CLK ↑
Tac (CL=3): 6.5nS
Tac (CL=2): 8.0nS
Tac RANGE: <PC-66> ↓
```

```
ACCESS TIME FROM CLK ↑
Tac (CL=3): 5.5nS
Tac (CL=2): 5.5nS
Tac RANGE: <PC133> ↓
```

The RAMCHECK program uses the Tac measurements to determine the test frequency of the module during Basic Test. A module, which indicates a Tac Range of <PC-133> will be run at 133MHz, a module with a Tac Range of <PC-100> will be run at 100MHz, and a module having a Tac Range of <PC-66> will be run at 83MHz. Other timing problems of the module may cause it to drift to lower speeds during Basic test or subsequent tests.

Please note that you can still override the speed (using Test Setup or the Change-on-the-Fly feature) to cause a module with a Tac measurement of even 8nS to run at 100MHz, but of course, such a module cannot meet the PC-100 specification of 6nS. Therefore, the fact that a module may run on RAMCHECK at 100MHz or more does not imply that the module is indeed PC-100 compliant.

Some modules which are not certified for PC-133 (and their SPD indicates that they are intended for PC-100) may still score within the <PC-133> range on RAMCHECK, as their access times are indeed quite fast. However, such modules may still exhibit unfavorable results in an actual PC-133 application, as there are several other factors involved in PC-133 compliance. On the same token, some PC-100 modules may slightly miss our margin of accuracy and score within the <PC-66> range.

An exact measurement of Tac requires the use of a very expensive tester with a variable temperature oven, sub-nanosecond accuracy,

and complex capabilities to compensate for all loading effects. RAMCHECK has an inherent inaccuracy of about +/-1 nS in determining the Tac measurements. Therefore, we are using the notion of Tac RANGE to allow for such measurement inaccuracies and to encourage the user to consider the actual Tac measurements. Other aspects of the RAMCHECK test (some still under development) are further used to determine compliance with the PC-133.

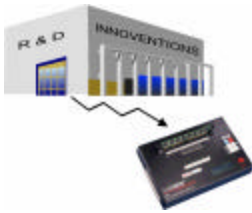

**The frequency list is subject to change with firmware development.**

Please note that unlike some of our competitors who measure speed by extrapolating access time measurements while running the modules at very slow clock rates (e.g. 25MHz), RAMCHECK actually runs the module at the indicated speed. For example, if a module is displayed to run at 133MHz, this is the exact clock rate that the RAMCHECK provides to the module (you can verify this fact with an oscilloscope connected to the module clock lines). RAMCHECK actually measures Tac by averaging a group of measurements done automatically at 66MHz, 75MHz, 83MHz, 100MHz, 112MHz, 125MHz, 133MHz, 150MHz, 166MHz, and 184MHz.

RAMCHECK can determine if a tested module is a PC-133, based on several actual measurements and a smart algorithm that takes into account the actual resolutions of the measurements of our test system.

The algorithm for determining PC-100 compliance uses various measurements made by the tester during the Basic Test. In particular, it uses information from maximum page burst frequency, frequency drift during test, the Tac measurements for CAS Latency 3 and 2, and the SPD data. It also allows for future enhancements when additional measurements will be available as our R&D efforts proceed.

The algorithm for determining PC-133 compliance employs similar methods as for PC-100. However, since the PC133 tests are conducted only on modules that have been detected as "at least" PC-100, a full understanding of our PC-100 determination is essential to understand our PC-133 determination.

The algorithm is a simplified Expert System, as it sometimes needs to judge between conflicting measurements. Therefore, our test summary screens (as well as the Test Log) provide a determination of PC-133/PC-100 compliance AND some of the results that led to that conclusion. Advanced users can further look at the results and determine the margin or accuracy of the RAMCHECK

determination.

This section provides the details for our PC-133/PC-100 reports.

## NOTATIONS

The following are examples of the first summary screen on RAMCHECK following the end of Basic Test. Alternatively, you can reach this screen even before the end of Basic Test if you abort the test by pressing F5 during Basic Test:

```
8Mx64'S SPEED: 100MHZ
TEST=PC-100
PAGE BURST=100MHZ
SPD=INTEL PC-100
```

```
8Mx72 SPEED: 133MHZ
TEST= PC133 RANGE
PAGE BURST=125MHZ
SPD=JEDEC PC133
```

The determination of the PC-133/PC-100 compliance appears on the second line of the screen and it has the header "TEST=" followed by "PC-100" if RAMCHECK determines that the module is PC-100, or "PC-133 RANGE" if RAMCHECK determines that the module is PC-133.

The third line of the first example indicates "PAGE BURST=100MHz" and it indicates that the maximum page burst of the tested module was 100MHz, while the second reached 125MHz. The fourth line of the first example indicates "SPD=INTEL PC-100" which indicates that the data in the SPD claims the module to be a PC-100. The second example indicates the SPD data matches that of a PC-133.

The next example shows the first summary screen of a PC-66 module:

```
2Mx64'S SPEED: 66MHZ
TEST=PC-66
PAGE BURST=100MHZ
SPD=INTEL PC-66
```

The message "TEST=PC-66" indicates that RAMCHECK has determined that the module is a PC-66. You can see that the bottom line also verifies that the SPD claims the module to be a PC-66.

The third example shows a module that is marked as PC-66 by the SPD, but RAMCHECK determines that the module matches the speed of other PC-100 modules:

```
4Mx72'S SPEED: 100MHZ
TEST=PC-100 RANGE
PAGE BURST=112MHZ
SPD=INTEL PC-66
```

The message "TEST=PC-100 RANGE" is indicating that the module indeed ran at 100MHz, even though the SPD data shows "SPD=INTEL PC-66". The maximum page burst in this example was 112MHz.

The first summary screen is followed by the Tac measurement screen as in the following examples:

```
8Mx64'S SPEED:
Tac (CL=3): 8.5ns
Tac (CL=2): 8.0ns
83MHZ <PC-66>
```

```
16Mx64'S SPEED:
Tac (CL=3): 5.0ns
Tac (CL=2): 5.5ns
100MHZ <PC-100>
```

In the case of the PC-133, RAMCHECK first detects that the module under test meets the PC-100 requirements. At that point, the SPD is checked for PC-133 compliance. Afterwards, the fast access time from clock at CL=3 is determined.

If the module can then work at 133MHz, the tester will determine that it is PC-133, showing the speed 133MHz during BASIC TEST and indicating a Tac range of PC-133 during the summary screen and in the test log.

```
16Mx64'S SPEED:
Tac (CL=3): 5.0ns
Tac (CL=2): 5.5ns
Tac RANGE: <PC133>
```

## INTERPRETATION OF RAMCHECK RESULTS

An exact measurement and full certification of a module as PC-133 requires the use of a very expensive tester with a variable temperature oven, sub-nanosecond accuracy, and complex capabilities to compensate for all loading effects. RAMCHECK has an inherent inaccuracy of about +/-1 nS in determining the Tac measurements. The patent pending page bursting mechanism of RAMCHECK provides a fairly accurate measurement of the maximum frequency in which the tested module can burst. By using an Expert System that gives a certain weight for each tested parameter, we are able to provide a close overall determination as to whether the module is PC-133, PC-100, or PC-66. However, 100% accuracy is beyond the scope of this inexpensive tester.

If a PC-133 module is identified as PC-100, or a PC-100 as a PC-

66, you can further investigate the measurements and see what margin of error exists.

If a PC-66 module is identified as "PC-100 RANGE", please note the module may or may not work in motherboards that require strict PC-100 compliance. This is why we use the RANGE notation.

*IMPORTANT NOTE:* The BASIC Test is the only test used by RAMCHECK to determine compliance for both PC-133 and PC-100 specifications. It provides an information summary that gives specific information if the module is compliant for either of these standards. Other frequencies are used throughout the Extensive Test to create additional conditions for the test. Therefore, if a module finishes BASIC Test as PC-133, the fact that it may run at 100MHz during Extensive Test or AUTO LOOP does not mean that the module is not a PC-133. Similarly, if a PC-100 device runs at 83MHz during the Extensive Test, it still remains a PC-100.